



Application

- Can be used to transfer clean water or other liquids similar to water in physical and chemical properties
- Suitable for small living water supply, automatic water sprinkler system, small air conditioner system or supporting equipment etc.

Pump

- Special anti-rust treatment for cast iron pump body and support
- Anti-block system for impeller
- Brass impeller
- AISI 304 shaft
- Max. liquid temperature: +40°C
- Max. suction: +8 m

Motor

- C&U bearing
- Motor with copper winding
- Built-in thermal protector for single phase motor
- Insulation class: F
- Protection class: IPX4
- Max. ambient temperature: +40°C
- IE 2 motor (AP110, AP150)

Identification Codes

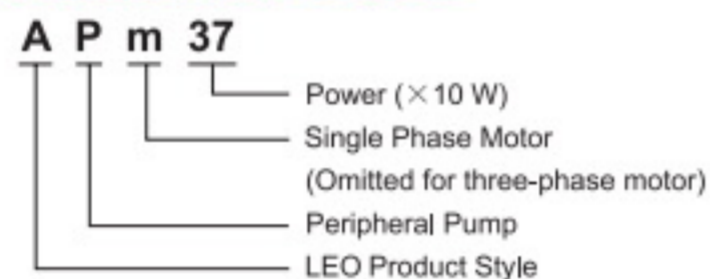

Technical Data

MODEL		POWER		Q (m³/h)																
Single Phase	Three Phase	kW	HP	Q (l/min)	0	0,3	0,6	0,9	1,2	1,5	1,8	2,1	2,4	3,0	3,6	4,2	4,8	5,4		
APm30	—	0.3	0.4	H (m)	30	26	20	15	12	8	5	-	-	-	-	-	-	-		
APm37	—	0.37	0.5		40	35	30	25	20	15	10	5	-	-	-	-	-	-		
APm60	—	0.6	0.8		60	55	50	40	35	30	25	20	10	5	-	-	-	-		
APm75	—	0.75	1.0		75	70	60	50	45	35	28	22	15	5	-	-	-	-		
APm90	—	0.75	1.0		90	75	60	50	35	25	15	5	-	-	-	-	-	-		
APm110	AP110	1.1	1.5		85	80	75	65	60	55	50	45	40	30	18	10	-	-		
APm150	AP150	1.5	2.0		90	86	80	75	70	65	60	55	50	40	30	20	10	-		
APm220	AP220	2.2	3.0		100	96	90	85	80	75	70	65	60	50	40	30	20	10		

Dimension

MODEL	DN1	DN2	L (mm)	W (mm)	H (mm)	L ₁ (mm)	L ₂ (mm)	L ₃ (mm)	W ₁ (mm)	H ₁ (mm)
APm30	1"	1"	260	132	155	46.5	80	8.5	100	63
APm37			260	132	155	46.5	80	8.5	100	63
APm60			282	147	183	51	90	8.5	112	71
APm75	3/4"	3/4"	300	147	183	54.5	90	8.5	112	71
APm90			297	147	183	50	90	8.5	112	71
APm110			336	165	210	56	100	9	125	86
APm150	1"	1"	338	165	210	56	100	9	125	86
APm220			395	170	235	56	123	12	140	96
AP220			338	165	210	56	100	9	125	86

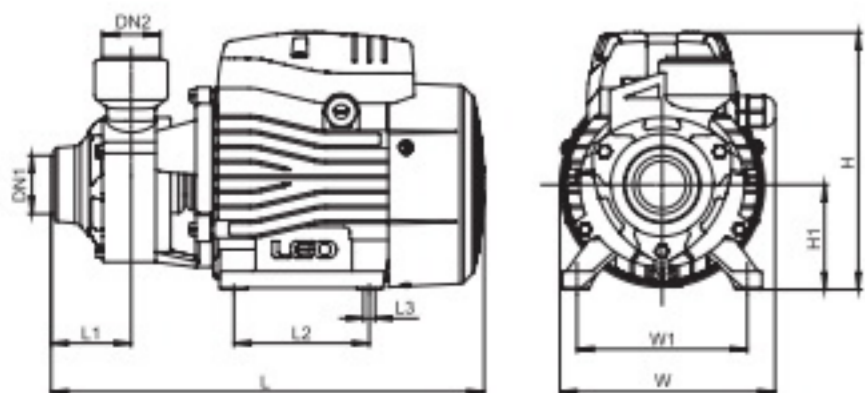

Hydraulic Performance Curves

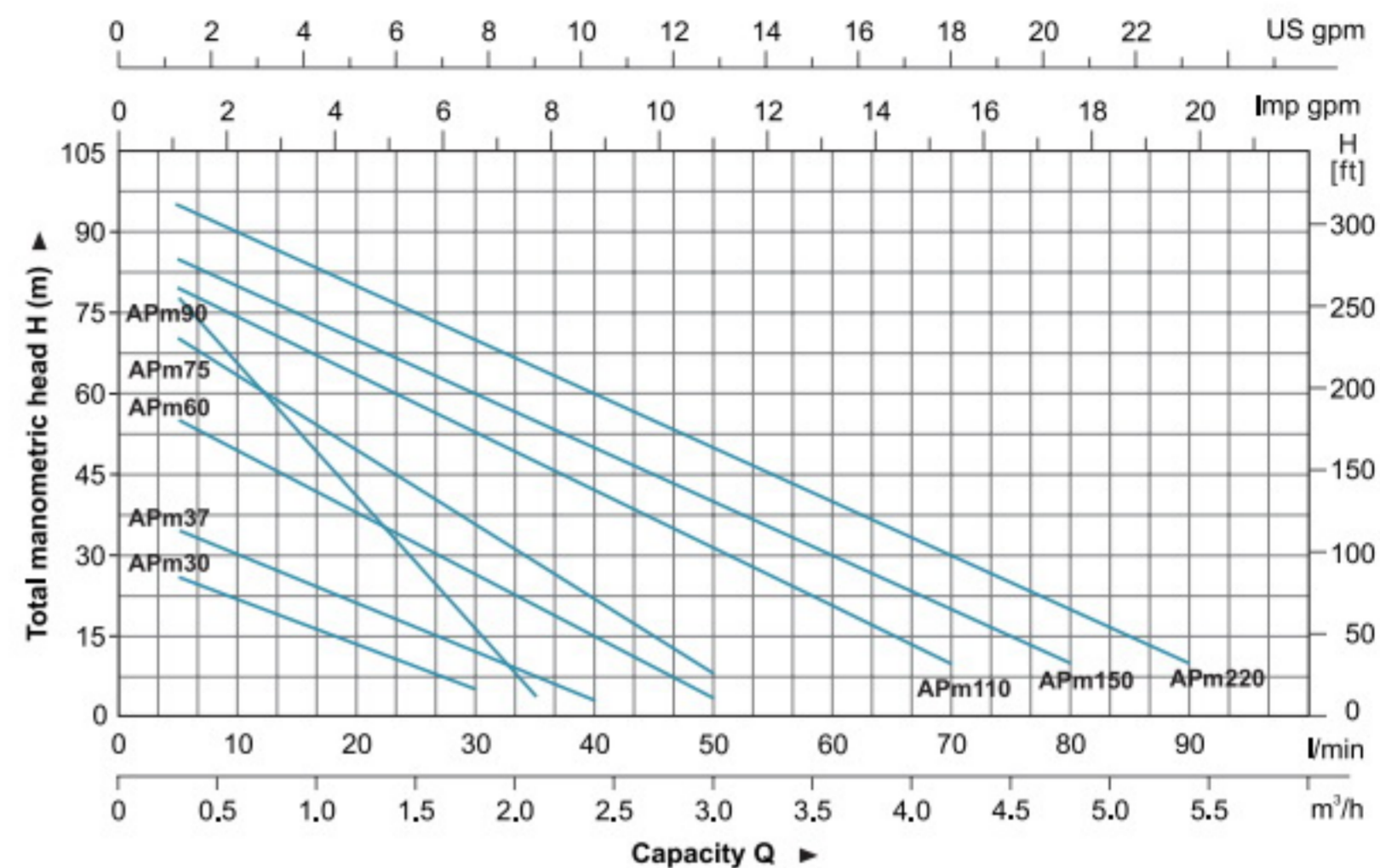

Materials Table

No.	Part	Material
1	Pump body	HT200
2	Impeller	Brass
3	Mechanical seal	Carbon/Ceramic
4	O-ring	NBR
5	Support	HT200
6	Bearing	
7	Rotor	
8	Fan cover	PP
9	Fan	PP
10	Rear cover	ZL102
11	Capacitor	
12	Terminal box	ABS
13	Terminal board	PC
14	Stator	
15	Filing plug	HPb50-1

No.	APm220 Part	Material
14-1	Stator	
14-2	Base	PC+ABS

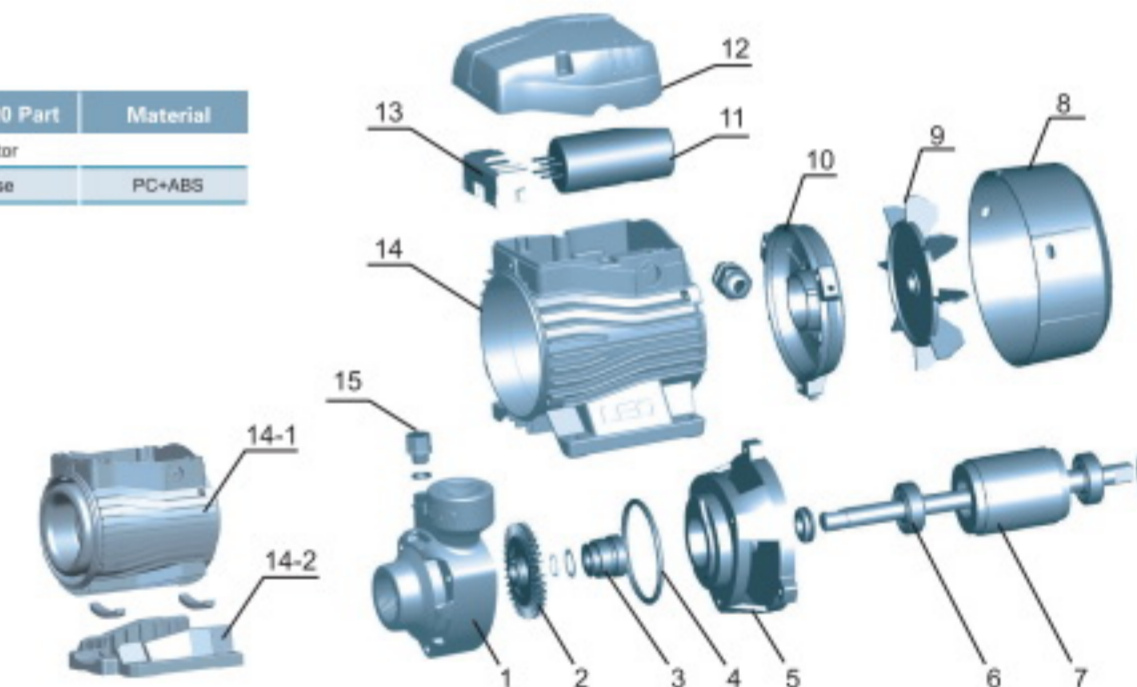

Package Information

Model	GW (Kgs)	L (mm)	W (mm)	H (mm)	Quantity (PCS/20 TEU)
APm30	5.1	283	158	171	3132
APm37	5.5	283	158	171	3132
APm60	9.0	315	190	210	2365
APm75	10.5	335	190	210	2222
APm90	10.5	335	190	210	2222
APm110	15.9	370	210	235	1230
APm150	16.5	370	210	235	1230
APm220	22.3	420	225	265	955
AP220	17.2	370	210	235	1230

